





94系列

/ /

94

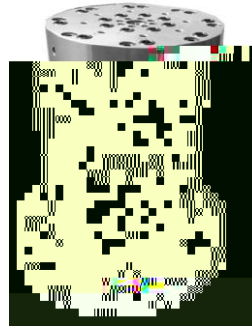

剖面结构

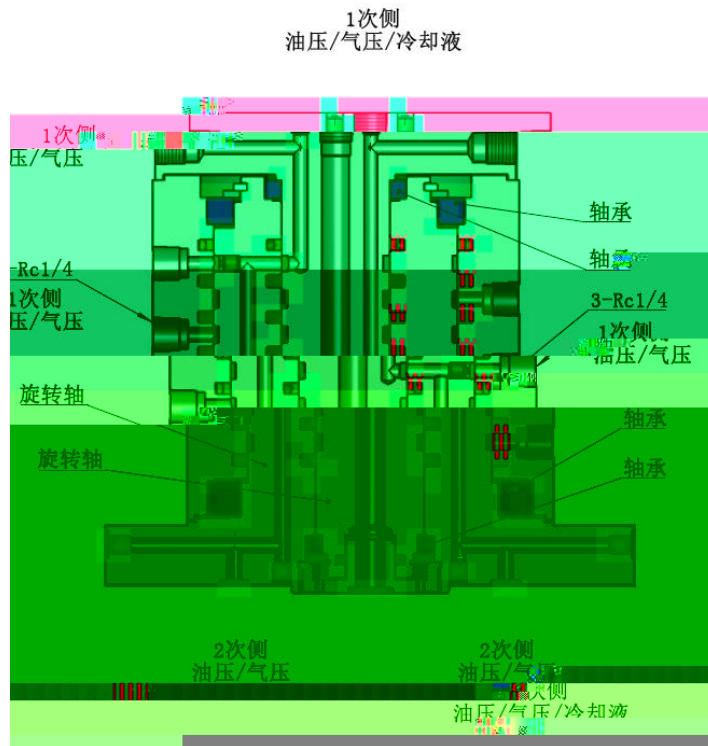

型号表示

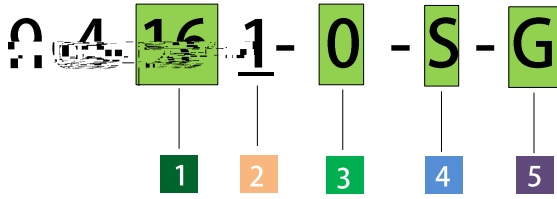

1 _____

4 _____

2 _____

5 _____

1

3 _____

0

规格

		941210	941610
Mpa		0 25	
		0 1.0	
		12	16
	mm ²	19.6	
		1	
		()	
(7MPa)	rpm	150	150
7MPa		0 70	
	N. m	63	100
	kg	21	32

外形及安装部位加工尺寸图: 941210

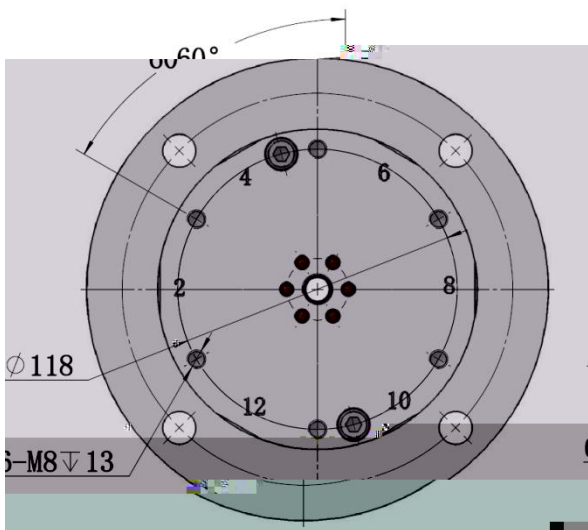
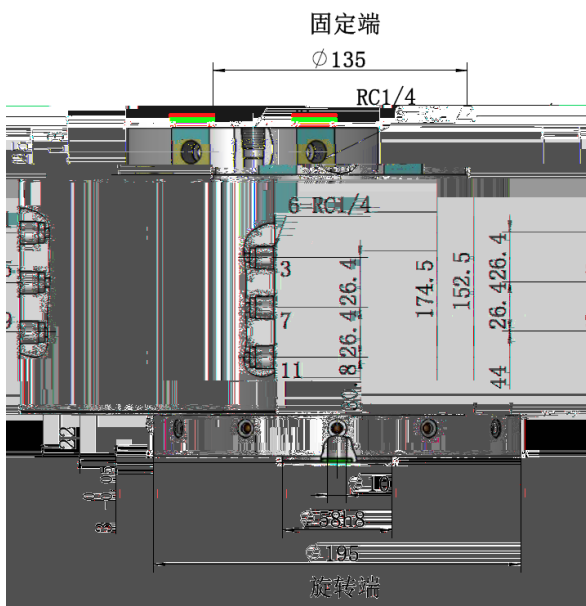
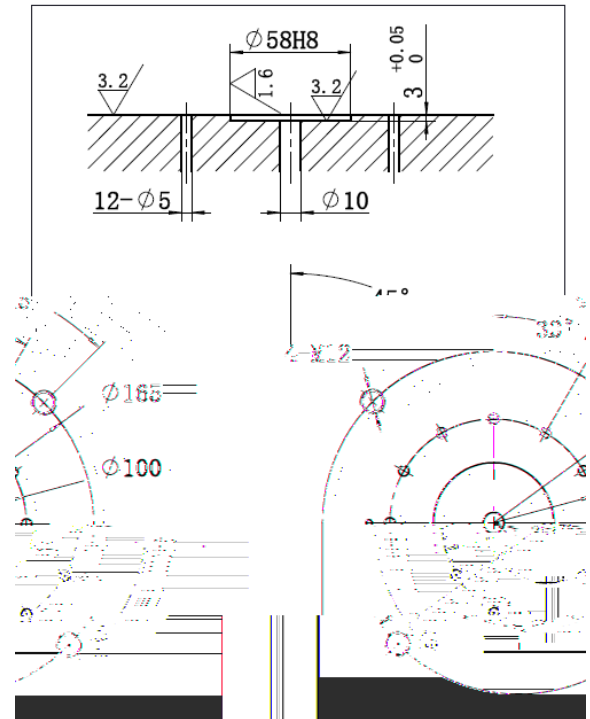
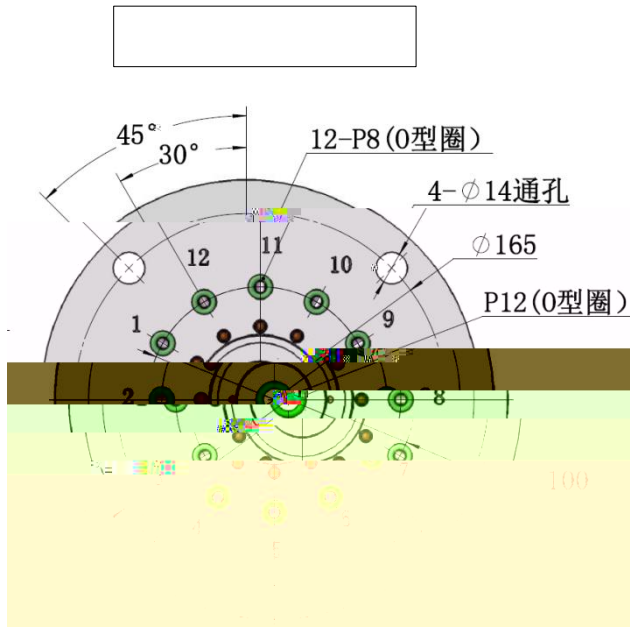

外形及安装部位加工尺寸图: 941610

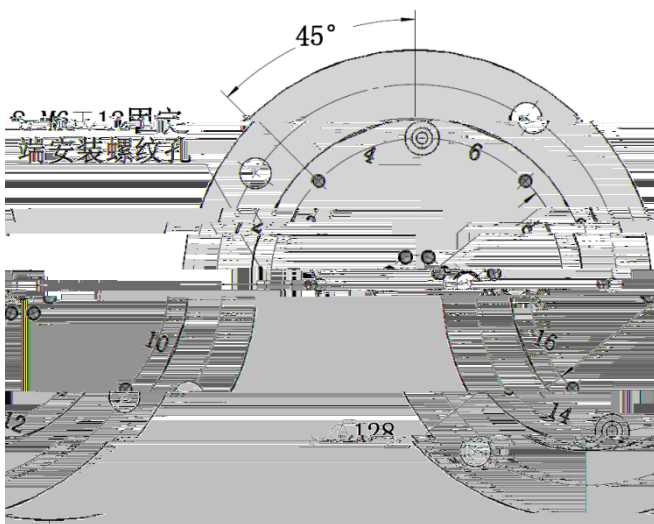
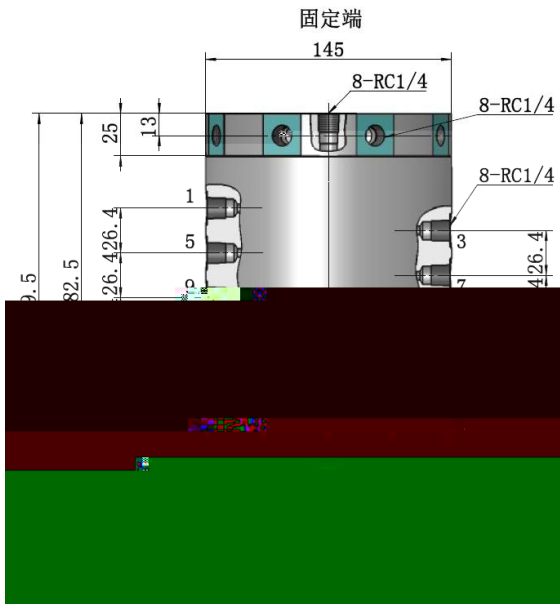
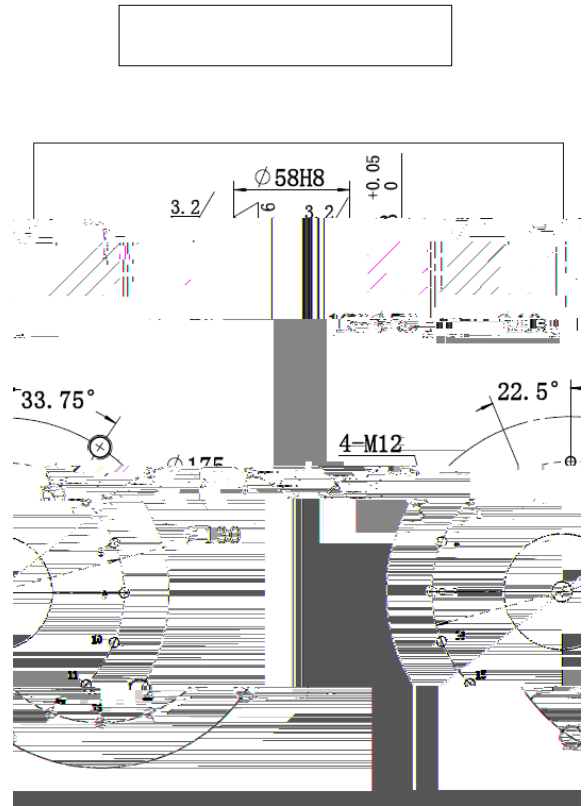
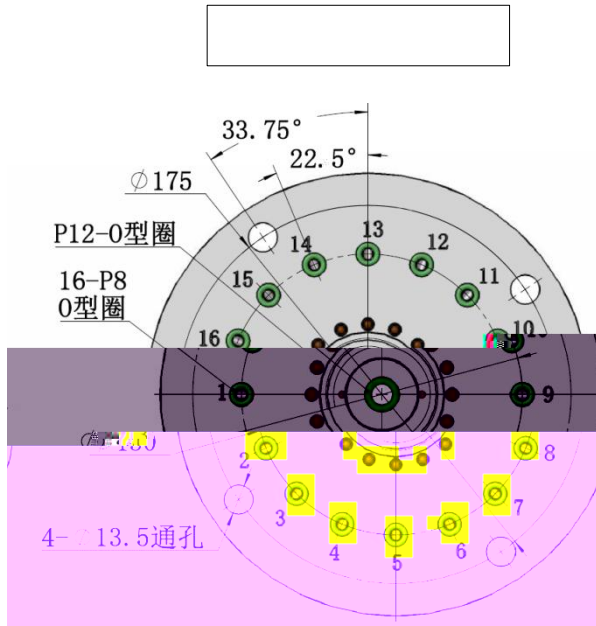

/ /

96



剖面结构

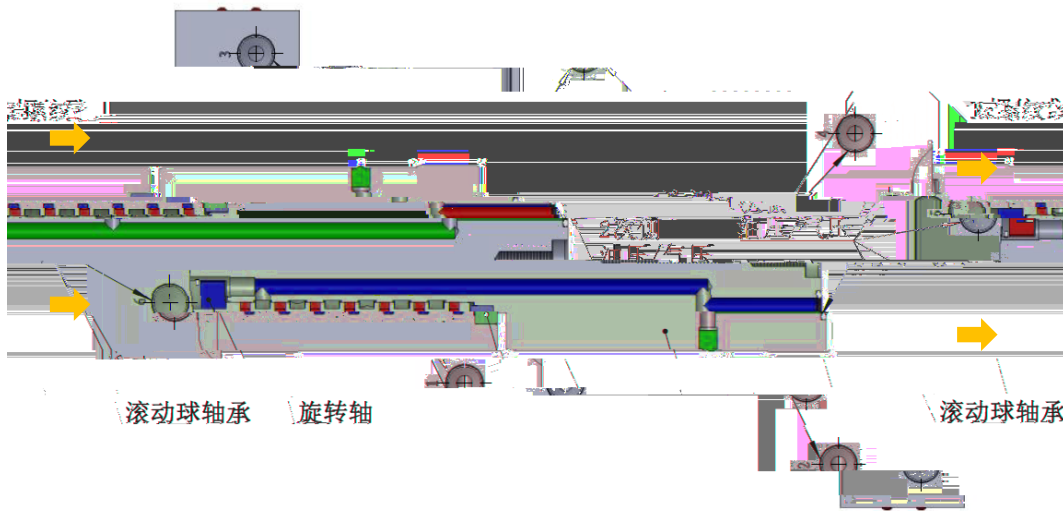

型号表示

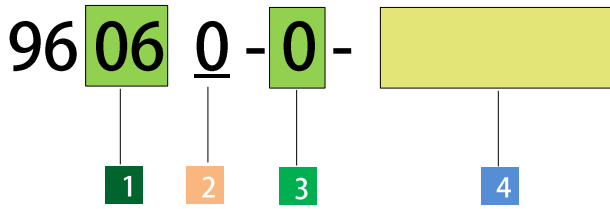

1 _____

3 _____

0

2 _____

4 _____

0

规格

		960200	960400	960600	960800
Mpa		0 7			
		0 1.0			
		2	4	6	8
	mm ²	12.6	12.6	19.6	19.6
(7MPa)	min ⁻¹	280	280	200	200
		0 70			

能力曲线表(转矩:参考值)

外形尺寸

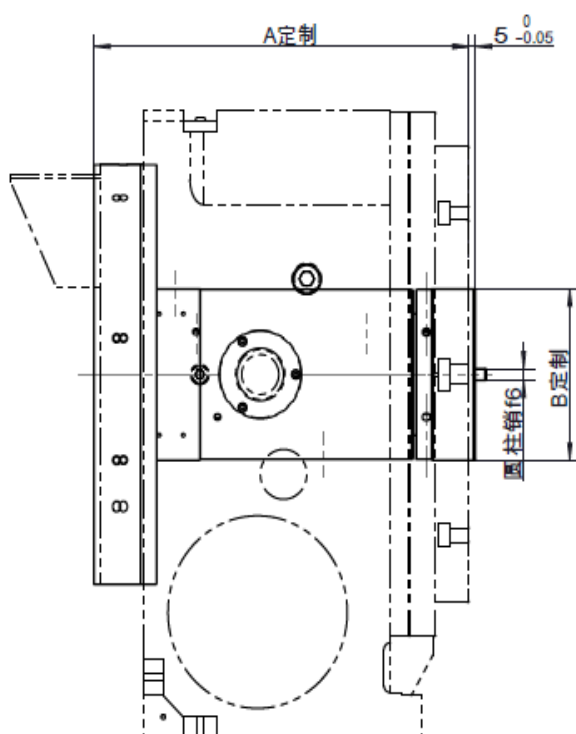

旋转侧

注:

- 1.该系列旋转接头除尺寸5为固定尺寸, 其余皆为定制尺寸;
- 2.根据客户提供转台型号定制。

/ /

98



油、气孔位置图：980210

油、气孔位置图：980410

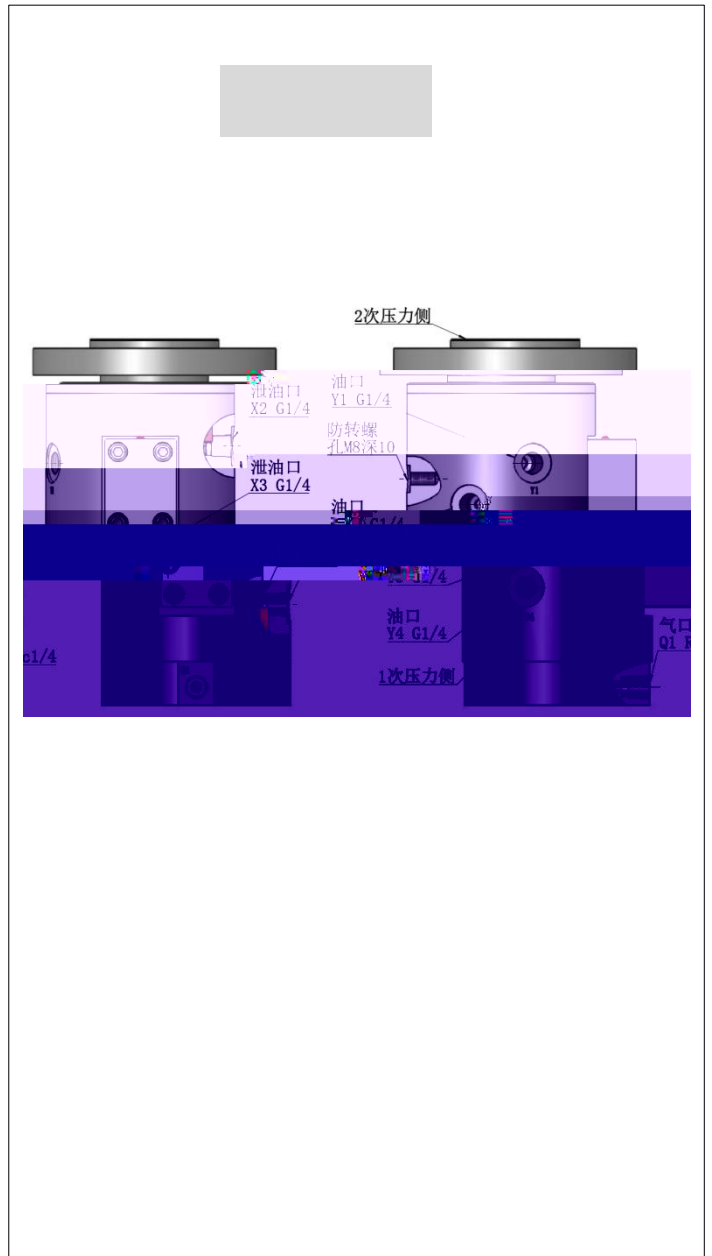
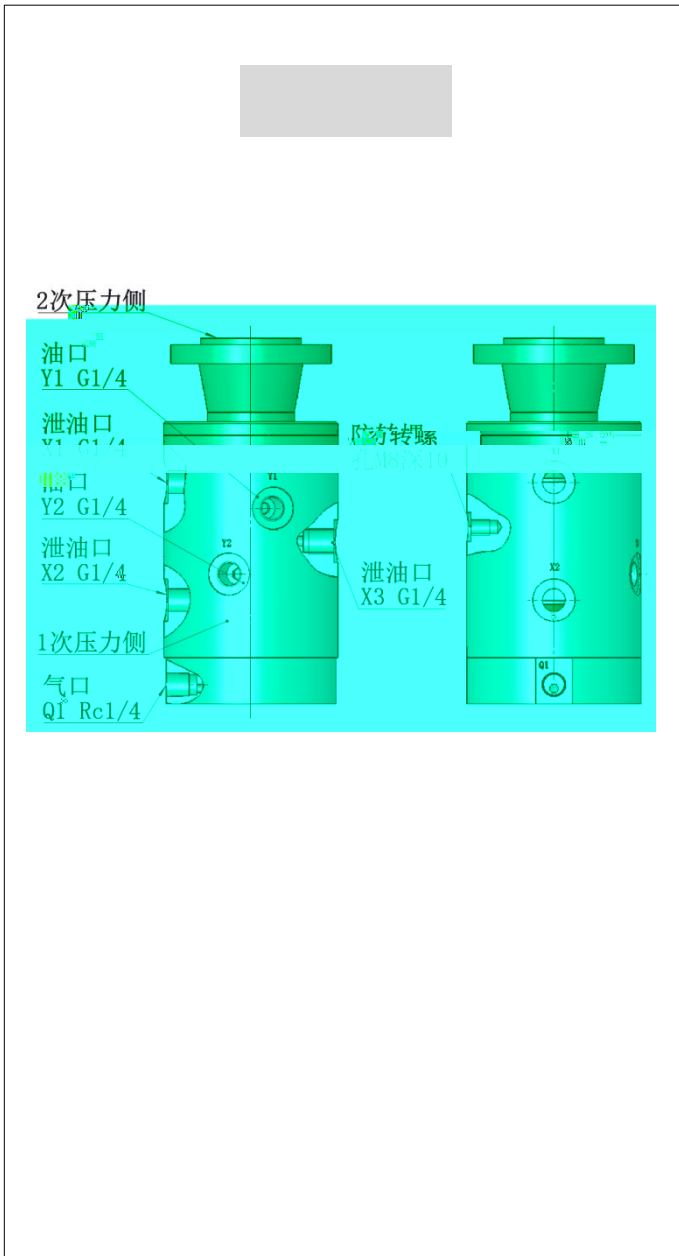

型号表示

9 8 **04** 1 **0** - **S** - **Λ**

1 2 3 4 5

1 _____

3 _____

0

4 _____

2 _____

0
1
2

5 _____

规格

		980210	980410
Mpa		0 7	
		0 1.0	
		2	4
	mm ²	19.6	28.26
		1	
	mm ²	19.6	
(7MPa)	rpm	2000	
	ml/min	300	600
(7Mpa)		0 70	
	N.m	3	5
	kg	7	15

外形尺寸：980210(980200)

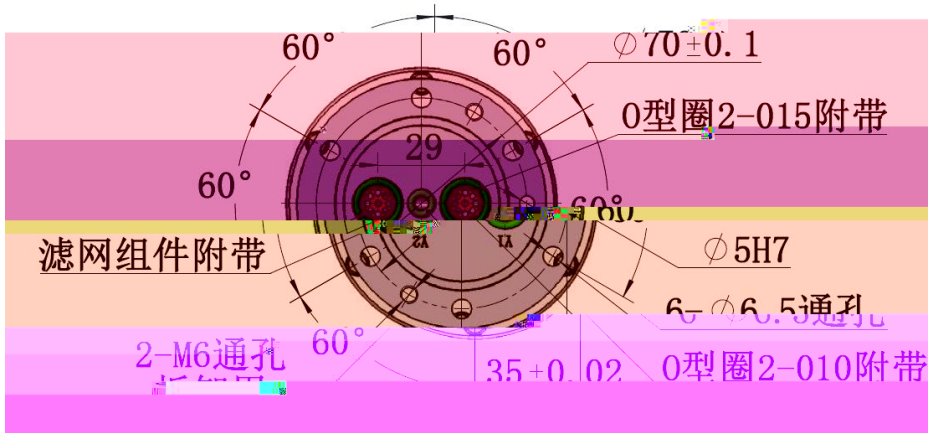
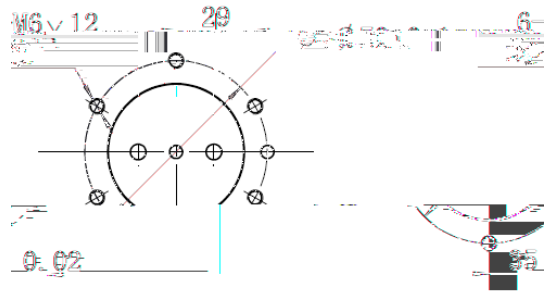
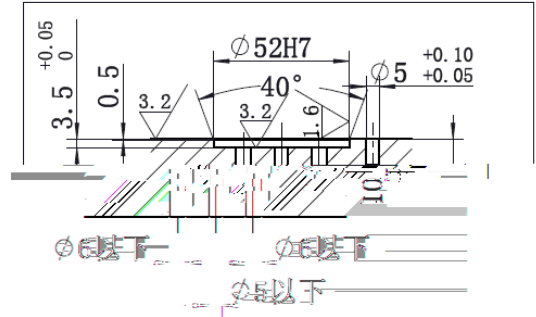
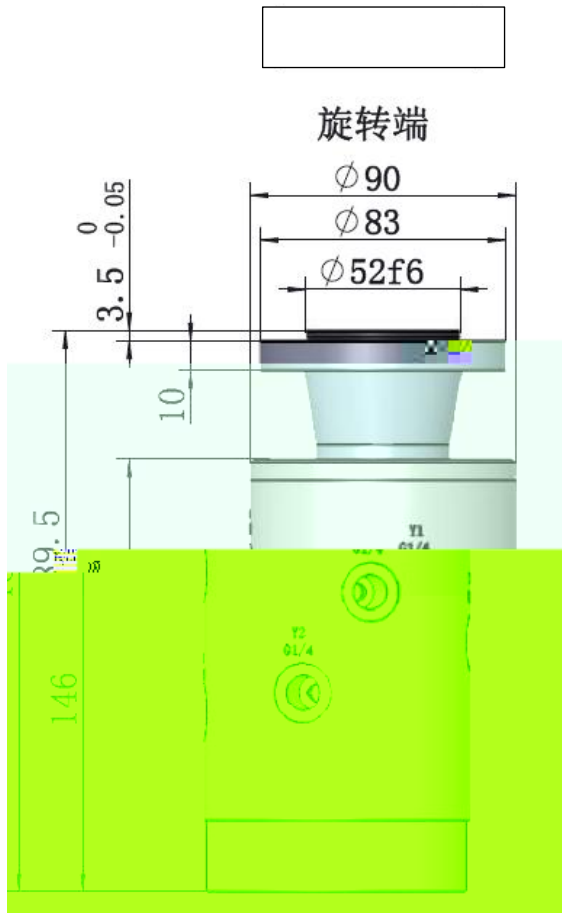

外形尺寸：980410(980400)

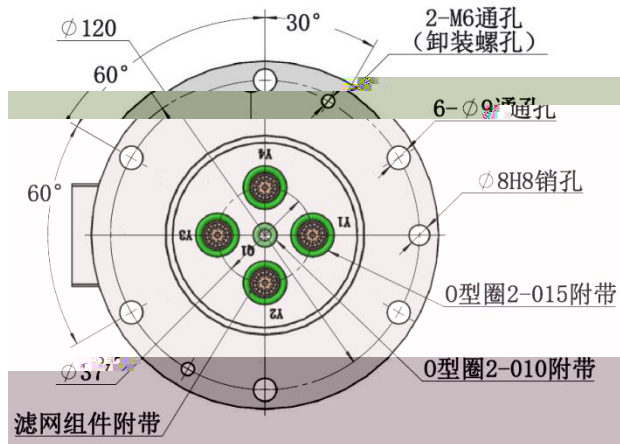
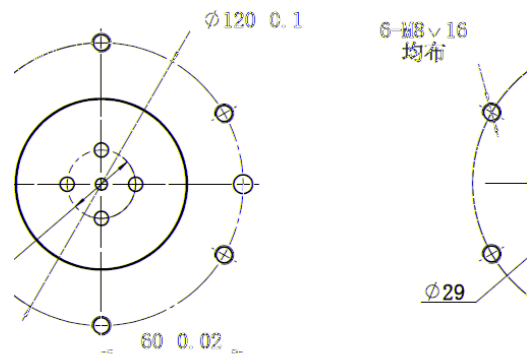
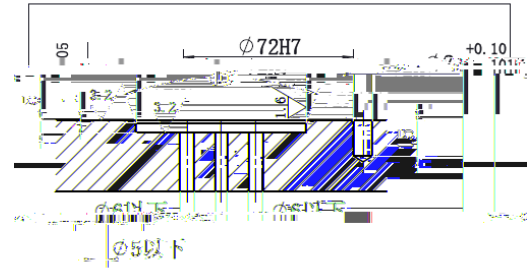
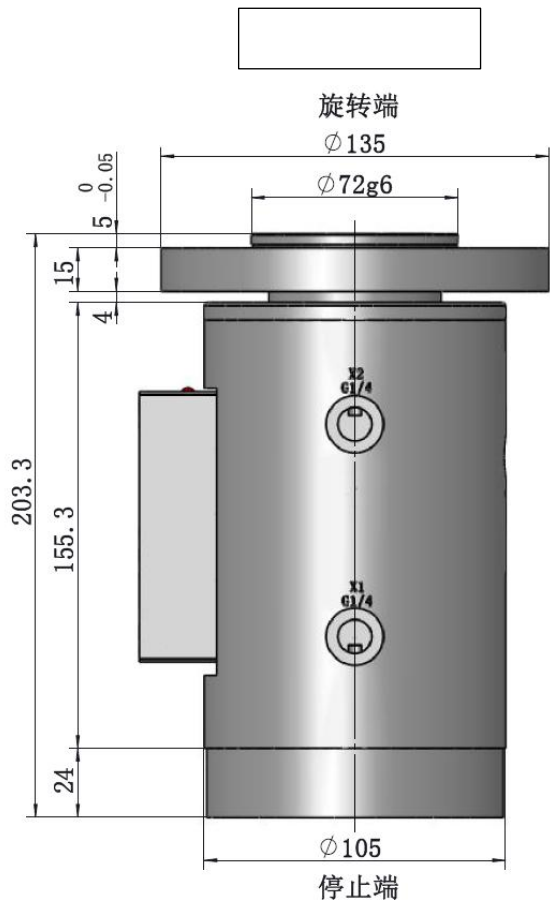

99



型号表示

9 9 **02** 0 0

1

2

1 _____

2 _____

0

规格

		990100	990200
Mpa		0	1.0
		1	2
	mm ²	50.24	
(7MPa)	rpm	5000	
		0 70	
	kg	0.35	1.05

外形尺寸：990100

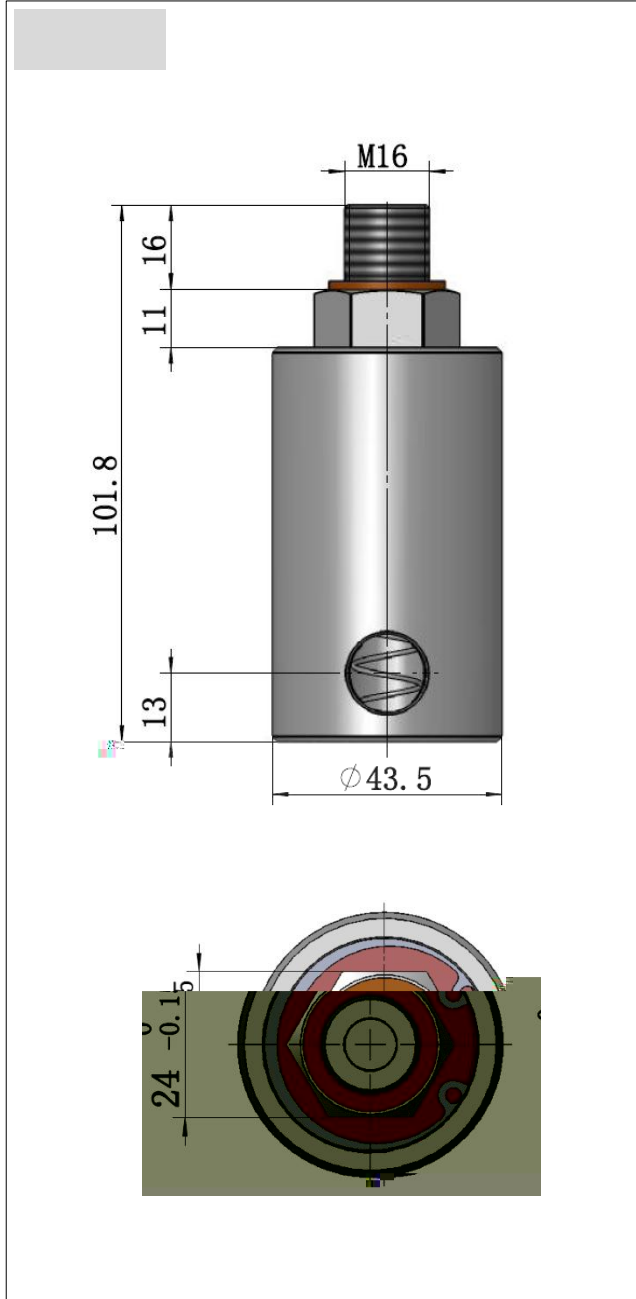

外形尺寸：990200

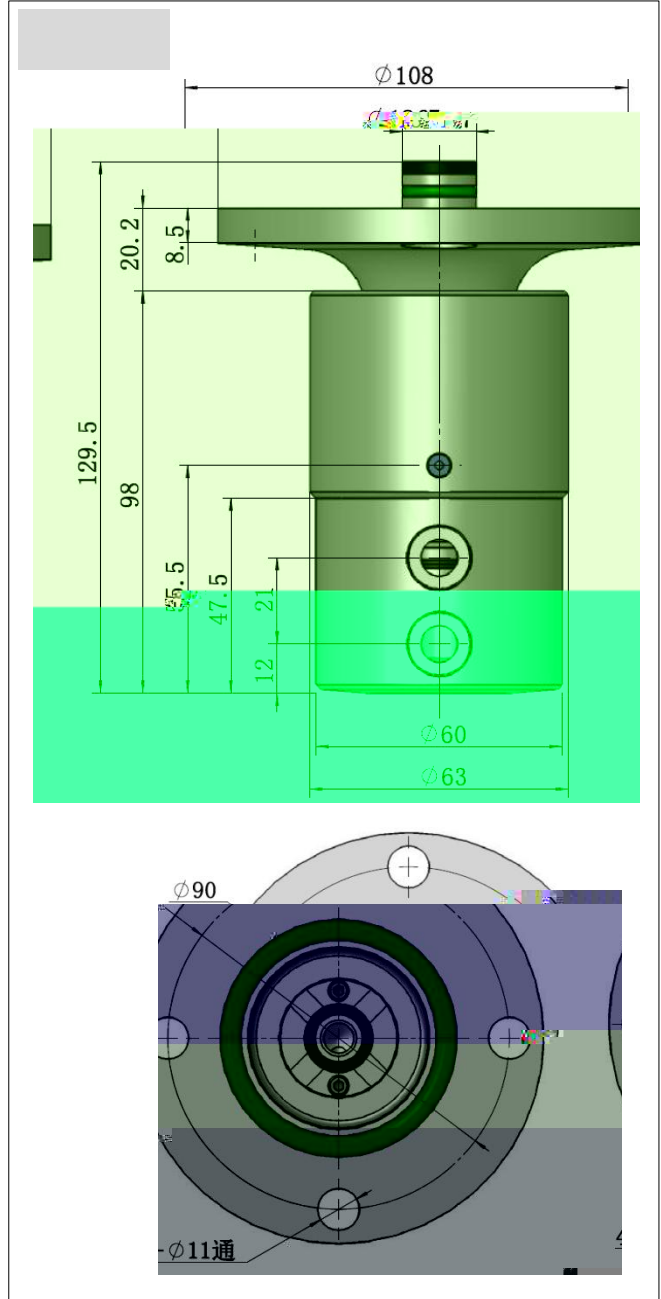

REKEDA

Work Clamping System

